



NEW HOLLAND

E 70 BSR

NEW HOLLAND KOBELCO



	STD	OFFSET
NET FLYWHEEL POWER	42 kW - 56 hp	
MAX OPERATING WEIGHT	7 835 kg	8 650 kg
BUCKET CAPACITY	0.23 - 0.35 m ³	



NEW HOLLAND

CONSTRUCTION

BUILT AROUND YOU

E70BSR*

TOP PERFORMANCE PACKED INTO
A VERY COMPACT MACHINE

Productivity (m³/l): + 22% vs. E70SR



- NEW** “iNDR” (integrated Noise & Dust reduction) cooling system
- NEW** environmentally friendly turbocharged engine
- NEW** generation hydraulic pump
- NEW** wide operator compartment
- NEW** hydraulic circuit
- NEW** easy to transport narrow version (NLC)

- The E70BSR represents an advanced example of Short Radius technology.
- It has been designed to satisfy customer needs, offering higher performance in terms of stability and productivity.
- This SR model features the revolutionary iNDR system that dramatically reduces machine noise level.
- Also a narrow (NLC) version is now available for customers who want a more flexible, easy to transport machine.
- Customers appreciate all the E70BSR features and benefits where space, easy transportation and noise are constraints on urban job sites and in construction.

* A product of the global alliance between New Holland and KOBELCO

RESEARCH & INNOVATION

INCREDIBLY QUIET
EFFECTIVE DUST PROTECTION
REMARKABLY EASY MAINTENANCE



**“Ultimate”
Low Noise Level
95dB(A)**

New Holland is proud to introduce also on E70BSR, the unique, innovative and **patented iNDR (integrated Noise & Dust reduction) Cooling System**, with the engine compartment placed inside a single duct that connects the air intake and the exhaust outlet which are offset. The design itself, together with the correct positioning the insulation material inside the duct, minimise the engine noise.

A SIMPLE SOLUTION GRANTS MANY ADVANTAGES

iNDR is a highly environmentally friendly solution which maximises operator comfort and allows work in urban areas with minimum disturbance to the public.

Furthermore the ultra cleaned air provided by iNDR contributes to perfect fuel combustion.

E70BSR

OPERATOR SAFETY & COMFORT

WIDER CAB INTERIOR

A new wider cab, the most spacious in its class, which features almost the same dimensions of a conventional excavator cab. The interior of the cab has been completely re-designed to maximise operator comfort and to enable optimum operator performance. All switches and controls are now ergonomically positioned on the right hand side, where they are easy to find and reach.

The new, more powerful and effective automatic air-conditioning system is standard equipment, creating an agreeable working atmosphere regardless of external weather conditions. At the same time, new interior design and materials create an elegant feeling. Rigid cab construction, combined with six silicon liquid filled viscous dampers, minimises vibrations.

Threaded holes, built into the cab structure, enable fast and easy attachment of optional FOPS structure and front guard, effectively contributing to operator safety.



NEW MONITOR

The new Monitor features an enlarged Display Screen to further enhance visibility.

Maintenance information and the self-diagnostic function provide an early warning. Any previous malfunction is also stored.



NEW ONE-HAND WINDSCREEN OPENING

One-touch lock release simplifies opening and closing the front window, while a new mechanism makes it lighter.

EASY MAINTENANCE & SERVICEABILITY

DESIGNED TO EFFECTIVELY CUT OPERATING COSTS



CLEAN AND ACCESSIBLE LAYOUT

The machine layout has been designed to make inspections, maintenance and servicing much easier and less time-consuming than in the previous model.

The engine oil filter, the fuel filter and the water separator are remote mounted and easy to reach from ground level. Both the fuel filter and the water separator, which removes contaminants and water, have an important function for engine performance and durability.

Cooling components (radiator, hydraulic oil cooler and intercooler) are now mounted in parallel, which gives increased cooling efficiency for higher component reliability whilst being easier to check and clean.



VISUAL CHECKING & EASY CLEANING OF iNDR FILTERS

The iNDR filters are located in front of the cooling components (radiator, hydraulic oil cooler and intercooler) now mounted in parallel for improved cooling efficiency.

The air goes directly from the intake duct through the iNDR stainless-steel filters which capture dust.

The cleaned air, going through the cooling components, reduces the risk of clogging and minimises the cleaning intervals of maintenance routine. If they appear dirty during the start up inspection, they are easy to remove without tools for cleaning from ground level.

LONG LIFE HYDRAULIC OIL

The long-life hydraulic oil used by New Holland features excellent anti-emulsion characteristics as well as an optimised mix of anti-wear and anti-oxidants additives that **boost the service life to 5,000 hours**, reducing the number of oil changes necessary and resulting in an impressive **reduction in operation costs and a higher respect for the environment**.

Automatic Fuel Electrical Pump is **standard equipment to optimise service time and maximise operator comfort**.

E70BSR

SPECIFICATIONS



ENGINE STAGE IIIA

Net flywheel power (ECE R120)	42 kW/56 hp
Rated rpm.....	2200
Make and model.....	ISUZU - AU-4LE2X
Type	Diesel 4-stroke, direct injection, turbo, aftercooler
Number of cylinders	4
Displacement	2179 cm ³
Bore x Stroke	85 x 96 mm
Maximum torque at 1600 rpm.....	200 Nm

Electronic engine rpm control dial type.

Auto-idling selector returns engine to minimum rpm when all controls are in neutral position.

The engine complies with requirements set by European Directive 97/68/EC (2004/26/EC)



ELECTRICAL SYSTEM

Voltage	24 V
Alternator.....	30 Amp
Starter motor.....	3.2 kW
Standard maintenance-free batteries	2
Capacity	64 Ah



HYDRAULIC SYSTEM

Load sensing closed centre hydraulic system with pressure compensating and flow sharing valves for fast cycles and simultaneous movements.

Operating mode selector: **H** - heavy mode for high performance
S - standard mode for normal operations

Manual selector: **A** - crusher mode
B - hammer mode

Main pump:

One variable displacement axial piston pump.

Pump automatically revert to zero delivery with controls in neutral
Maximum delivery
 132 l/min |

Piloting circuit: gear type pump

Maximum delivery
 18 l/min |

Maximum operating pressure:

Equipment/Travel	29.4 MPa
Swing	24.5 MPa
Blade	27.5 MPa
Pilot circuit	3.5 MPa

Hydraulic cylinders	Number	Bore	Stroke
Lift	1	110 mm	916 mm
Offset	1	100 mm	564 mm
Penetration	1	95 mm	833 mm
Bucket	1	80 mm	735 mm
Blade	1	120 mm	125 mm



TRANSMISSION

Type.....	hydrostatic, two-speed
Travel motors	2, axial piston type, double displacement
Brakes.....	automatic discs type
Final drive.....	oil bath, planetary reduction
Gradeability (continuous)	70% (35°)

Travel speeds

Low	from 0 to 2.8 km/h
High	from 0 to 5.3 km/h

Automatic DownShift device: to move travel motors to maximum displacement position with selector on "speed" when greater traction is required.

Drawbar pull
 72 kN |



SWING

Swing motor	axial piston type
Swing brake	automatic discs type
Final drive.....	oil bath, planetary reduction
Swing Ring	oil bath type
Swing Speed	12.7 rpm



CAB AND CONTROLS

Transparent upper cab roof.

Automatic conditioning.

Controls.....piloted

Two cross path pattern levers actuate all equipment movements and superstructure swing.

One lever for blade lower/lift.

Two pedals with "hand" levers control all track movements, counter-rotation included.

A safety lever completely neutralizes the piloting circuit.



UNDERCARRIAGE

X-frame undercarriage design.

Heavy duty track chain with sealed bushings.

Rollers:	LC	NLC
Track rollers (each side)	5	5
Carrier rollers (each side)	1	1
Length of track on ground (mm)	2240	2240
Gauge (mm)	1870	1700
Shoes triple grousers (mm)	450 - 600	450
Rubber (mm)	450	450



BLADE (STANDARD)

Redesigned dozer blade to improve reliability, durability and performance

Width x Height
 2320/2470 x 460 mm |

Lift above ground
 355 mm |

Digging depth
 250 mm |



CAPACITIES

Engine	litres
Lube oil.....	11.0
Coolant.....	8.5
Fuel tank	120.0
Hydraulic system.....	90.0
Swing drive gear	1.5
Travel drive (each).....	5.3

ONE - PIECE BOOM

DIMENSIONS (mm) - OPERATING WEIGHTS

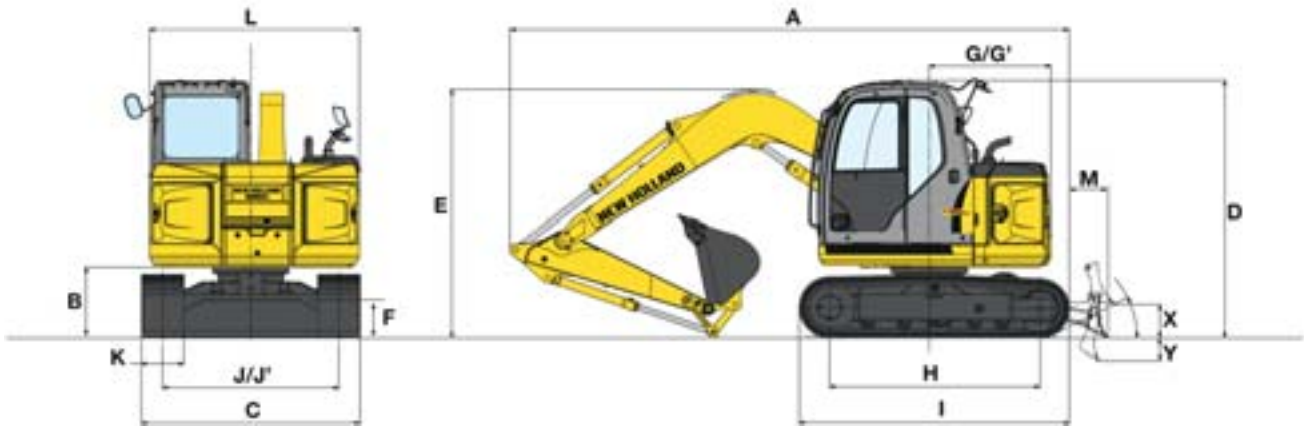

ARM	A	B	D	E	F	G/G'	H	I	J/J'	L	M
1710 mm	5830	730	2740	2630	360	1290/1300	2240	2860	1870/1700	2230	410
2130 mm	5970	730	2740	2960	360	1290/1300	2240	2860	1870/1700	2230	410

G' = Rear swing radius with additional (0.40 t) bolt-on counterweight (optional)

J = LC version gauge

J' = NLC version gauge

		STEEL - 3 GROUSERS	RUBBER
K - Shoe width	mm	450	600
C - maximum width**	mm	2320/2150	2470/2300
Operating weight with blade**	kg	7600/7545	7835/-
Ground pressure	bar	0.34	0.26
Blade width	mm	2320	2470 (*)
Blade height	mm	460	460 (*)
Blade weight	kg	500	515 (*)
X - max lift	mm	355	355 (*)
Y - max dig.	mm	250	250 (*)

(*) not available for NLC version

** LC/NLC version

DIGGING PERFORMANCE

ONE PIECE BOOM = 3840 mm

DIPPERSTICK		1710	2130
A	mm	6460	6850
B	mm	6300	6700
C	mm	4160	4580
D	mm	7390	7690
E	mm	5330	5630
F	mm	2530	2220
G	mm	3450	3860
H	mm	1760	2010

BREAKOUT FORCE			
Bucket	daN	5400	5400
Dipperstick	daN	4000	3550

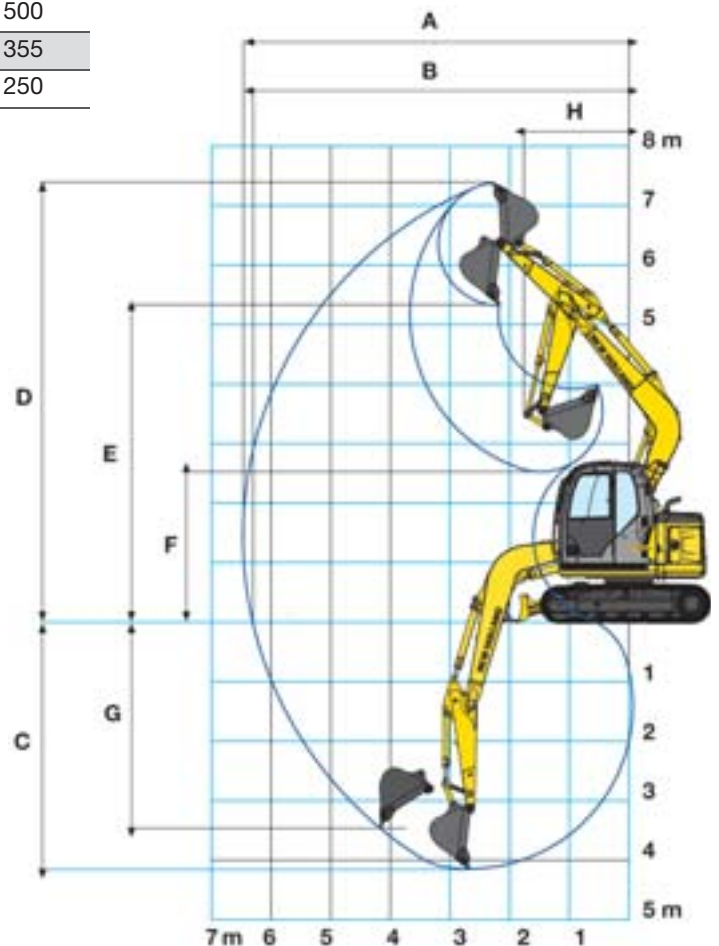

OFFSET BOOM

DIMENSIONS (mm) - OPERATING WEIGHTS

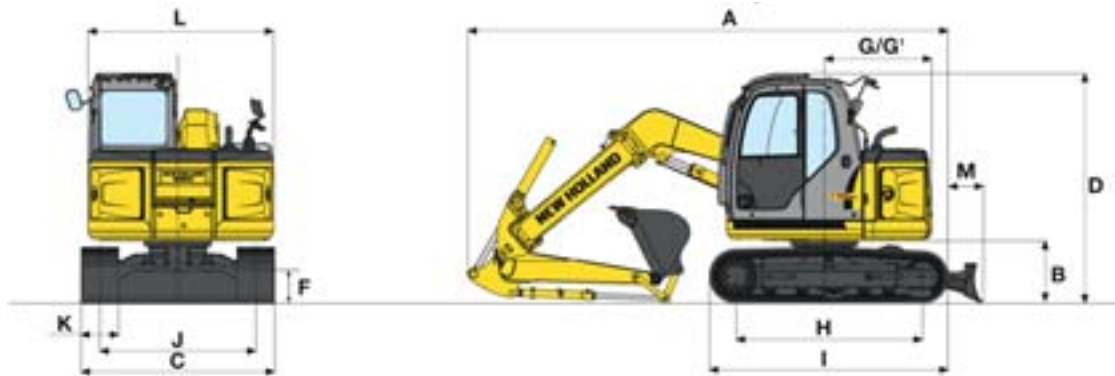

ARM	A	B	D	F	G/G'	H	I	J	L	M
1870 mm	5760	730	2760	360	1290/1300	2240	2860	1870	2230	410
2160 mm	6190	730	2760	360	1290/1300	2240	2860	1870	2230	410

G'= Rear swing radius with additional (0.40 t) bolt-on counterweight (optional)

		STEEL - 3 GROUSERS	RUBBER
K - Shoe width	mm	450	600
C - maximum width	mm	2320	2470
Operating weight with blade	kg	8420	8650
Ground pressure	bar	0.37	0.29
Max blade width	mm	2320	2470
Blade height	mm	460	460
Blade weight	kg	500	515
X - max lift	mm	500	500
Y - max dig.	mm	590	590

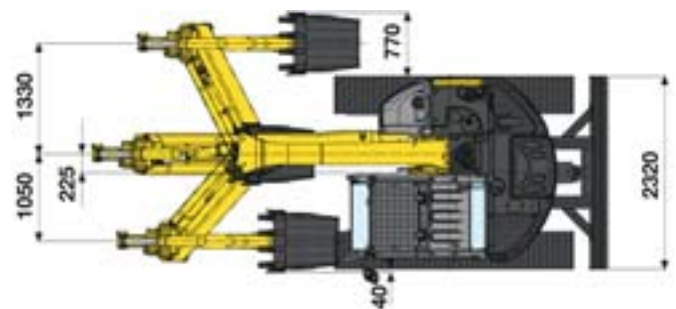

DIGGING PERFORMANCE*

DIPPERSTICK		1860	2160
A	mm	6550	6810
B	mm	6390	6660
C	mm	4210	4510
D	mm	7710	7910
E	mm	5640	5850
F	mm	2510	2220
G	mm	3320	3580
H	mm	1200	1280

BREAKOUT FORCE			
Bucket	daN	5380	5380
Dipperstick	daN	3990	3540

* At max. offset the above dimensions are reduced by average 350 mm on the left side and 650 mm on the right side.

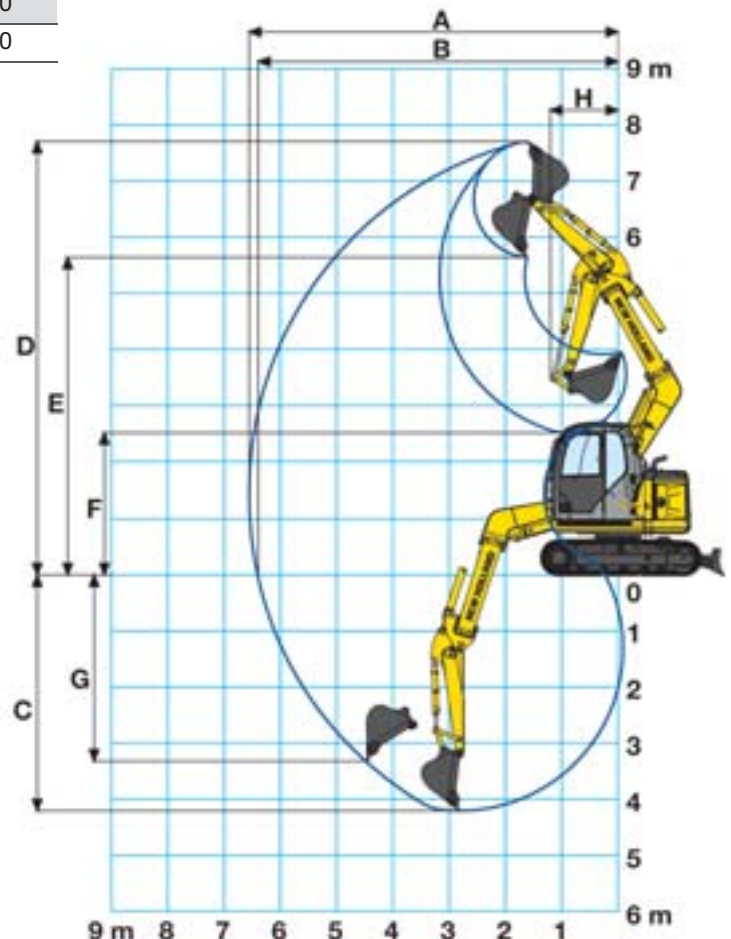

LIFTING CAPACITY

All data intended with blade up

VALUES ARE EXPRESSED IN TONNES

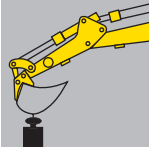
	REACH									
	1.5 m		3.0 m		4.5 m		AT MAX REACH			
	FRONT	SIDE	FRONT	SIDE	FRONT	SIDE	FRONT	SIDE	REACH m	

E70BSR-LC ONE-PIECE BOOM - 1710 mm DIPPERSTICK

HEIGHT	1.5 m		3.0 m		4.5 m		AT MAX REACH		REACH m
+6.0 m			1.7 *	1.7 *			1.5 *	1.5 *	3.15
+4.5 m			1.9 *	1.9 *	1.5 *	1.3	1.3 *	1.2	4.64
+3.0 m	4.7 *	4.7 *	2.5 *	2.5 *	1.5	1.2	1.1	0.9	5.34
+1.5 m			2.8	2.2	1.4	1.1	1.0	0.8	5.56
0			2.6	2.0	1.3	1.1	1.0	0.8	5.37
-1.5 m	4.1 *	4.1 *	2.5	2.0	1.3	1.0	1.2	1.0	4.70
-3.0 m	2.4 *	2.4 *	1.7 *	1.7 *			1.5 *	1.5 *	3.28

E70BSR-LC ONE-PIECE BOOM - 2130 mm DIPPERSTICK

HEIGHT	1.5 m		3.0 m		4.5 m		AT MAX REACH		REACH m
+6.0 m							1.3 *	1.3 *	3.82
+4.5 m					1.6 *	1.3	1.2	1.0	5.12
+3.0 m			2.2 *	2.2 *	1.5	1.3	0.9	0.8	5.76
+1.5 m			2.8	2.3	1.4	1.2	0.8	0.7	5.96
0			2.5	2.0	1.3	1.1	0.8	0.7	5.78
-1.5 m	3.5 *	3.5 *	2.5	1.9	1.3	1.0	1.0	0.8	5.17
-3.0 m	3.4 *	3.4 *	2.1 *	2.0			1.5 *	1.3	3.93

E70BSR-LC ONE-PIECE BOOM - 2130 mm DIPPER - HEAVIER CWT*

HEIGHT	1.5 m		3.0 m		4.5 m		AT MAX REACH		REACH m
+6.0 m							1.3 *	1.3 *	3.82
+4.5 m					1.6 *	1.5	1.2 *	1.1	5.12
+3.0 m			2.2 *	2.2 *	1.7	1.4	1.0	0.9	5.76
+1.5 m			3.0 *	2.4	1.5	1.3	0.9	0.8	5.96
0			2.8	2.2	1.4	1.2	0.9	0.8	5.78
-1.5 m	3.5 *	3.5 *	2.7	2.1	1.4	1.1	1.1	0.9	5.17
-3.0 m	3.4 *	3.4 *	2.1 *	2.1 *			1.5 *	1.4	3.93

E70BSR-LC ONE-PIECE BOOM - 2130 mm DIPPER - + 400 kg CWT**

HEIGHT	1.5 m		3.0 m		4.5 m		AT MAX REACH		REACH m
+6.0 m							1.3 *	1.3 *	3.82
+4.5 m					1.6 *	1.5	1.2 *	1.2 *	5.12
+3.0 m			2.2 *	2.2 *	1.7	1.5	1.1	0.9	5.76
+1.5 m			3.0 *	2.6	1.6	1.3	1.0	0.8	5.96
0			2.9	2.3	1.5	1.2	1.0	0.8	5.78
-1.5 m	3.5 *	3.5 *	2.9	2.3	1.5	1.2	1.2	1.0	5.17
-3.0 m	3.4 *	3.4 *	2.1 *	2.1 *			1.5 *	1.5 *	3.93

E70BSR-LC ONE-PIECE BOOM - 2130 mm DIPPER - HEAVIER CWT* + 400 kg CWT**

HEIGHT	1.5 m		3.0 m		4.5 m		AT MAX REACH		REACH m
+6.0 m							1.3 *	1.3 *	3.82
+4.5 m					1.6 *	1.6 *	1.2 *	1.2 *	5.12
+3.0 m			2.2 *	2.2 *	1.7 *	1.6	1.2 *	1.0	5.76
+1.5 m			3.0 *	2.8	1.7	1.5	1.1	0.9	5.96
0			3.2	2.5	1.6	1.4	1.1	0.9	5.78
-1.5 m	3.5 *	3.5 *	3.1	2.5	1.6	1.3	1.3	1.1	5.17
-3.0 m	3.4 *	3.4 *	2.2 *	2.2 *			1.5 *	1.5 *	3.93

* HEAVIER Counterweight = + 260 kg (higher density material filled on)

** BOLT-ON Counterweight = + 400 kg

The table values refer to ISO 10567 for excavator equipped with bucket. The indicated load is no more than 87% of hydraulic system lift capacity or 75% of static tipping load. Values marked with an asterisk are limited by the hydraulic system.

LIFTING CAPACITY

All data intended with blade up

VALUES ARE EXPRESSED IN TONNES

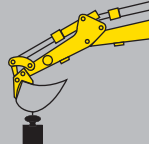
	REACH							
	1.5 m		3.0 m		4.5 m		AT MAX REACH	
	FRONT	SIDE	FRONT	SIDE	FRONT	SIDE	FRONT	SIDE

E70BSR-NLC ONE-PIECE BOOM - 1710 mm DIPPER - HEAVIER CWT*

HEIGHT	1.5 m		3.0 m		4.5 m		AT MAX REACH		REACH m
	FRONT	SIDE	FRONT	SIDE	FRONT	SIDE	FRONT	SIDE	
+6.0 m			1.7 *	1.7 *			1.5 *	1.5 *	3.15
+4.5 m			1.9 *	1.9 *	1.5 *	1.2	1.3 *	1.1	4.64
+3.0 m	4.7 *	4.7 *	2.5 *	2.2	1.5	1.1	1.1	0.8	5.34
+1.5 m			2.7	1.9	1.4	1.0	1.0	0.7	5.56
0			2.5	1.7	1.3	0.9	1.0	0.7	5.37
-1.5 m	4.0 *	4.0 *	2.5	1.7	1.3	0.9	1.2	0.8	4.70
-3.0 m	2.5 *	2.5 *	1.7 *	1.7 *			1.5 *	1.5 *	3.28

E70BSR-NLC ONE-PIECE BOOM - 2130 mm DIPPER - HEAVIER CWT*

HEIGHT	1.5 m		3.0 m		4.5 m		AT MAX REACH		REACH m
	FRONT	SIDE	FRONT	SIDE	FRONT	SIDE	FRONT	SIDE	
+6.0 m							1.3 *	1.3 *	3.82
+4.5 m					1.6 *	1.2	1.2	0.9	5.12
+3.0 m			2.2 *	2.2 *	1.5	1.1	0.9	0.7	5.76
+1.5 m			2.8	1.9	1.4	1.0	0.8	0.6	5.96
0			2.5	1.7	1.3	0.9	0.8	0.6	5.78
-1.5 m	3.5 *	3.5 *	2.5	1.6	1.2	0.8	1.0	0.7	5.17
-3.0 m	3.4 *	3.4 *	2.1 *	1.7			1.5 *	1.1	3.93

E70BSR-NLC ONE-PIECE BOOM - 2130 mm DIPPER - HEAVIER CWT* + 400 kg CWT**

HEIGHT	1.5 m		3.0 m		4.5 m		AT MAX REACH		REACH m
	FRONT	SIDE	FRONT	SIDE	FRONT	SIDE	FRONT	SIDE	
+6.0 m							1.3 *	1.3 *	3.82
+4.5 m					1.6 *	1.4	1.2 *	1.1	5.12
+3.0 m			2.2 *	2.2 *	1.7 *	1.4	1.2 *	0.9	5.76
+1.5 m			3.0 *	2.4	1.7	1.3	1.1	0.8	5.96
0			3.2	2.2	1.6	1.2	1.1	0.8	5.78
-1.5 m	3.5 *	3.5 *	3.1	2.1	1.6	1.1	1.3	0.9	5.17
-3.0 m	3.4 *	3.4 *	2.2 *	2.2 *			1.5 *	1.4	3.93

* HEAVIER Counterweight = + 260 kg (higher density material filled on)

** BOLT-ON Counterweight = + 400 kg

The table values refer to ISO 10567 for excavator equipped with bucket. The indicated load is no more than 87% of hydraulic system lift capacity or 75% of static tipping load. Values marked with an asterisk are limited by the hydraulic system.

LIFTING CAPACITY

All data intended with blade up

VALUES ARE EXPRESSED IN TONNES

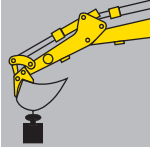
	REACH							
	1.5 m		3.0 m		4.5 m		AT MAX REACH	
	FRONT	SIDE	FRONT	SIDE	FRONT	SIDE	FRONT	SIDE

E70BSR-LC OFFSET BOOM - 1860 mm DIPPER - STD HEAVIER CWT*

HEIGHT	1.5 m		3.0 m		4.5 m		AT MAX REACH		REACH m
	FRONT	SIDE	FRONT	SIDE	FRONT	SIDE	FRONT	SIDE	
+6.0 m			0.5 *	0.5 *			2.0 *	2.0 *	3.26
+4.5 m			0.5 *	0.5 *	1.7	1.4	1.5	1.3	4.71
+3.0 m			2.6 *	2.4 *	1.6	1.3	1.1	0.9	5.40
+1.5 m			2.8	2.2	1.4	1.1	0.9	0.7	5.62
0			2.5	1.9	1.3	1.0	0.9	0.7	5.43
-1.5 m			2.4	1.8	1.2	1.0	1.1	0.9	4.77
-3.0 m			1.5 *	1.5 *			1.3 *	1.3 *	3.38

E70BSR-LC OFFSET BOOM - 2160 mm DIPPER - STD HEAVIER CWT*

HEIGHT	1.5 m		3.0 m		4.5 m		AT MAX REACH		REACH m
	FRONT	SIDE	FRONT	SIDE	FRONT	SIDE	FRONT	SIDE	
+6.0 m							1.7 *	1.7 *	3.70
+4.5 m					1.7	1.5	1.4	1.1	5.03
+3.0 m			1.8 *	1.8 *	1.6	1.3	1.0	0.8	5.68
+1.5 m			2.9	2.3	1.4	1.2	0.9	0.7	5.89
0			2.5	1.9	1.3	1.0	0.8	0.7	5.70
-1.5 m			2.4	1.8	1.2	0.9	1.0	0.8	5.08
-3.0 m			1.9 *	1.9 *			1.4	1.3	3.81

E70BSR-LC OFFSET BOOM - 2160 mm DIPPER - STD HEAVIER CWT* + 400 kg CWT**

HEIGHT	1.5 m		3.0 m		4.5 m		AT MAX REACH		REACH m
	FRONT	SIDE	FRONT	SIDE	FRONT	SIDE	FRONT	SIDE	
+6.0 m							1.7 *	1.7 *	3.70
+4.5 m					1.8 *	1.6	1.5 *	1.3	5.03
+3.0 m			1.8 *	1.8 *	1.8	1.5	1.2	1.0	5.68
+1.5 m			3.3	2.6	1.7	1.3	1.0	0.8	5.89
0			2.9	2.3	1.5	1.2	1.0	0.8	5.70
-1.5 m			2.8	2.2	1.4	1.1	1.2	0.9	5.08
-3.0 m			1.9 *	1.9 *			1.4 *	1.4 *	3.81

* HEAVIER Counterweight = + 260 kg (higher density material filled on)

** BOLT-ON Counterweight = + 400 kg

The table values refer to ISO 10567 for excavator equipped with bucket. The indicated load is no more than 87% of hydraulic system lift capacity or 75% of static tipping load. Values marked with an asterisk are limited by the hydraulic system.

PARTS AND SERVICE

The New Holland dealer network is, in itself, the best guarantee of continued productivity for the machines it delivers to its customers. New Holland service technicians are fully equipped to resolve all maintenance and repair issues, with each and every service point providing the high standards they are obliged to observe under New Holland's stringent quality guidelines. The New Holland global parts network ensures fast, reliable, replacement parts for less downtime, increased productivity and, of course, profitable operation for its customers.



AT YOUR OWN DEALERSHIP

The information contained in this brochure is intended to be a general nature only. The NEW HOLLAND KOBELCO CONSTRUCTION MACHINERY S.p.A. company may at any time and from time to time, for technical or other necessary reasons, modify any of the details or specifications of the product described in this brochure. Illustrations do not necessarily show products in standard conditions. The dimensions, weights and capacities shown herein, as well as any conversion data used, are approximate only and are subject to variations within normal manufacturing techniques.

Published by NEW HOLLAND KOBELCO CONSTRUCTION MACHINERY S.p.A.
Printed in Italy - LEADER Firenze - Cod. 30 468GB - Printed 04/09

Printed on recycled paper
CoC-FSC 000010 CQ Mixed sources



ELEMENTAL
CHLORINE
FREE
GUARANTEED

FIAT
GROUP



www.newholland.com