



# NEW HOLLAND

## W190<sub>B</sub>



MAXIMUM POWER	169 kW - 227 hp
MAX OPERATING WEIGHT	17 600 kg
BUCKET CAPACITY	3.1 - 3.5 m <sup>3</sup>



**NEW HOLLAND**

CONSTRUCTION

BUILT AROUND YOU

# W190B

THE NEW

## T NEW CNH TIER 3A ENGINE

The new turbo, aftercooled, electronically controlled CNH engine mounted on W190B is a jewel of technology which utilises the direct injection **Common Rail** and **EGR** systems to drastically reduce fuel consumption, noise and pollution.

It features **4 valves** per cylinder, a bigger displacement **6.7 litres (+14%)**, higher maximum power **169 kW (+13%)** at lower r.p.m., increased maximum torque respect the previous model and an electronically controlled **Multiple Work Modes**.

## T NEW HYDRAULIC SYSTEM

The new **Load Sensing, Closed Centre** hydraulic system, with two variable displacement pistons pumps, delivers its power when and where it is needed. It also allows simultaneous movements independently from power required and engine r.p.m.

Steering effectiveness and safety are assured by a **demand valve** which prioritizes the diversion of necessary flow from one of the two pumps to the **emergency steering** gear pump, which is independent and automatic.

A high efficiency system that contributes towards improved fuel economy, reduced heat generation and which optimizes cycles and production.



# LOOK OF PERFORMANCE

## **T** NEW EXCLUSIVE COOLING SYSTEM

The New Holland advanced and **exclusive Cooling Module**, is a cube positioned in the centre of the machine with all radiators mounted around three of its sides and the hydraulic tank positioned in the centre, to optimise both space and cooling effect. A hydraulically driven fan, automatically actuated by a thermostatic sensor, draws fresh and clean air from outside through the radiators and the tank and blows it over the engine to the rear of the machine. The fan is reversible to easily clean the radiators. The tank position, high on the pumps, eliminates risk of cavitation. A real innovation that enhances component efficiency and durability.

## **F** NEW ZF AXLES

Front and rear axles are produced by ZF and feature:

- **Standard Limited Slip differential**
- **HD outboard planetary reduction final drives**
- **Maintenance-free outboard wet disc brakes**
- **Rear axle oscillation up to 24°**

All that means improved traction on slippery ground conditions, extended tyre life thanks to reduced spin, reduced axles shaft stress by developing torque at the wheels and enhanced confidence when working on rough and uneven ground for higher safety, durability and reduced operating costs.

## **A** NEW SPACE LAB CAB

A modern, safe and comfortable cab featuring:

- Bucket corners, wheels and 360° outstanding visibility
- Easy entrance thanks to a **580 mm** wide door and inclined stair with larger anti-slip steps
- Internal volume increased by **13%**
- integrated **ROPS** and **FOPS** structure and tinted safety glass
- Standard pressurization and optional climatisation
- Fingertip loader control

A cab designed to grant maximum operator comfort and safety for increased production and profitability.

## **T** NEW MACHINE STRUCTURE

The front frame has been redesigned and the bucket pin height increased by **50 mm**. The steering cylinders are now mounted on the rear frame to drastically reduce the number of hoses in the articulation point.

In addition, the engine has been moved to the back of the rear frame which, together with the **140 mm** increase in wheel base, contributes to the perfect stability of the new W190B.

**A completely new, stable, reliable and high-performance unit providing maximum return on investment in the shortest time.**



# W190B THE POWER

## NEW TIER 3A COMMON RAIL ENGINE



**T**his new CNH Common Rail engine is a jewel of technology, designed to reduce fuel consumption and pollution.

It features a bigger displacement **6.7 litres**, higher maximum power **169 kW**, lower crankshaft revolution 2000 r.p.m. (versus 2175 r.p.m. of the previous model), increased maximum torque at lower r.p.m. **100 daNm at 1400 r.p.m.** (versus 86 daNm at 1500 r.p.m.) and electronically controlled **Multiple Work Modes**.

The **Common Rail** system assures the injection of fuel in the cylinders at very high pressure, optimizing nebulization and mix with an increased quantity of turbocharged and after-cooled air, thus delivering a perfect and total fuel combustion.

In addition, the **EEMS** (Engine Electronic Management System) controls the “right moment” to introduce the “right quantity” of fuel in the cylinders.

These features provide **higher engine efficiency and lower fuel consumption** and, thanks to the **EGR (Exhaust Gas Recirculation)**, part of the exhaust gas is reintroduced in the cylinders, reducing the combustion temperature and contributing to **reduced emissions of Particulate and of NOx**, the production of which are proportional to the combustion temperature.

This electronically controlled CNH engine features **Multiple Work Modes**. The operator can select one of the following electronically pre-set power modes, depending on the type of job in hand:

**Maximum power:** 169 kW/227 hp, for very tough conditions

**Standard power:** 157 kW/210 hp, for normal loading conditions

**Economy power:** 142kW/190 hp, for light load and carry applications.



An **Automatic power mode** can be also selected to automatically match the engine power curve, between maximum power and standard power, to the machine application.

A new, durable, efficient, comfortable and economic engine which contributes to reduced operating costs and increased profits.

# OF DURABILITY & EFFICIENCY

## INTEGRATED HYDRAULIC AND STEERING SYSTEM



**T**he W190B hydraulic system consists of two variable displacement, axial pistons pumps mounted in series and **Load Sensing** regulated. One pump delivers 120 l/min to the front loader only, at a maximum pressure of 250 bars. The second pump, with the same delivery and pressure prioritizes its flow to the steering system via a **demand valve**. If steering is not required, all the hydraulic oil, including the flow of the second pump, is available for the front loader to delivery fast, efficient and productive cycles.

A small gear pump driven by an electric motor, which automatically switches on in case of engine shutoff, provides **emergency steering**, for operator safety and comfort.

The **closed centre** piloted control valve allows simultaneous movement under every load and engine speed condition. In addition, controls are power assisted, with electromagnetic detent and the loader section of the control valve includes floating function.

Hydraulics and Steering: an integrated system which features operator comfort as well as top class safety, controllability and efficiency.



# W190B THE POWER

## THE EXCLUSIVE NEW HOLLAND COOLING MODULE

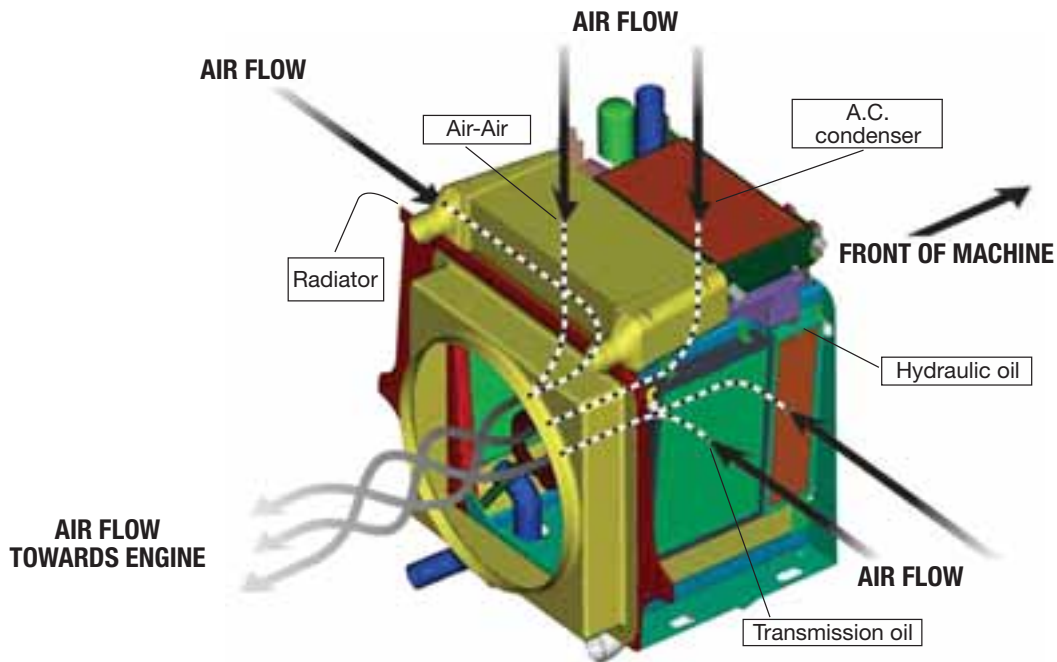

### **T** A.C.S. (Advanced Cooling System) The exclusive New Holland Cooling Module

This exclusive Cooling Module looks like a cube positioned in the centre of the machine. All radiators are located around three sides of the cube to optimise both space and cooling effect. The coolant radiator is on the left-hand side while the hydraulic oil and transmission oil radiators are positioned in parallel on the opposite side. The engine after-cooler radiator and the air conditioner condenser are on top of the cube, also fitted in parallel.

To optimise the cooling effect of a fresh and clean air flow, the hydraulic oil tank is located inside the cube and can be easily reached thanks to the hinged liftable condenser of the airconditioning system. The position of the hydraulic tank, high above the pumps, avoids the risk of cavitation, increasing pumps durability.

A variable speed hydrostatic fan, automatically actuated by a thermostatic sensor, with eight plastic blades, draws fresh and clean air from outside through the radiators and the hydraulic oil tank.

A switch in the cab allows the operator to select the fan counter rotation for easy and automatic radiators cleaning.

**A real comfortable, durable, and efficient improvement offered by New Holland.**



# OF NOVELTY



## BETTER BALANCE

The introduction of the compact and centrally mounted **Cooling Module** results in a wider free space in the back of the rear frame.

This innovative solution has allowed the New Holland engineers to reposition the engine and its components all the way back on the rear frame.

Consequently, the centre of gravity is also moved backwards in a more convenient position to better counterbalance the loading effect. Therefore, whilst maintaining the previous good stability, it has been possible to reduce the weight of the rear counterweight - a necessary but "**dead**" weight. A modern engine hood, which enhances rear visibility, has also been added.

Optimum stability with less "dead" weight and better rear visibility means greater operator safety and confidence, shorter cycle time, higher productivity: all which adds up to higher profitability.

# W190B THE POWER



## SPACE LAB CAB

The New Holland W190B is now equipped with a completely new designed and advanced cab featuring outstanding internal and external improvements.



“Space” means that:

- access to the cab has been improved thanks to the **580mm** wide door (80mm wider), which can be locked back at 180 deg., and to the new, wider inclined stair with larger anti-slip steps.
- internal volume has been **increased by 13%** and the glass area enhanced to provide perfect bucket and 360 deg. visibility.
- the steering column is tiltable and includes a high-tech dashboard, enabling easy functional checks from every position.
- the new contoured and suspended seat, adjustable in all directions, incorporates a retractable seat belt and adjustable armrests. It can be supplied with optional head rest to let the operator work with maximum comfort in an extremely low noise atmosphere.



# OF SAFETY & COMFORT

- “**Lab**” means an advanced laboratory where
- vital information on the main components is provided by the new on-board computer and displayed on the new multi-language, high-tech digital LCD screen located on the dashboard just in front of the operator for easy reading;
  - the "car standard" cab features an integrated **ROPS and FOPS structure** with tinted safety glass.
  - standard pressurization, optional climatisation and FM radio, low noise level and modern and elegant interiors provides the operator with pleasant and comfortable working conditions, regardless of the external weather conditions.



A machine cab several steps ahead of the rest in terms of state-of-the-art technology. A cab designed to provide maximum operator comfort and safety, allowing him to fully concentrate on the job in hand for better performance and higher productivity.



# W190B THE POWER

## MAINTENANCE AND SERVICE



The W190B is designed for simple and easy maintenance and service procedures thanks to its excellent ground level access to all the most important components and to the new high-tech digital display located on the dashboard, which keeps the operator fully aware of all machine main functions, such as engine and transmission diagnostics, error reporting and warning prompts.

Wide side panels, that open and close with a seagull wing movement, are light to lift and automatically self-locking in a safety position thanks to compressed air cylinders.

# OF ECONOMY

They give immediate access to most of the engine components, including the high pressure injection pump, alternator, fuel/water separator, engine oil filter, fuel filter, air filter and the engine electronic control panel.

Access to the hydraulic tank is provided by a third lifttable panel, which is located on the top of the engine hood, behind the cab.

Grouped together in a protected and easily-accessible remote position on the rear left side of the machine are the engine oil, coolant and hydraulic oil valves, allowing easy and ecological discharge of fluids. All this adds up to maximum comfort, safety, efficiency and economy in the day-to-day use of the New Holland W190B.



# W190B SPECIFICATIONS



## ENGINE TIER 3A

Maximum power (ISO 14396/ECE R 120-SAE J 1995) ..169 kW/227 hp  
 Net flywheel power (SAE J1349).....159 kW/213 hp  
 Rated engine speed .....2000 rpm  
 Make and model .....CNH 667TA/EBD  
 Type.....Diesel, Common rail, turbo, aftercooler, electronic injection  
 Total displacement .....6.7 l  
 N° of cylinders .....6  
 Bore x stroke .....104 x 132 mm  
 Maximum torque at 1400 rpm.....100 daNm  
 Lubrication with gear pump

The engine conforms to European requirements for "low exhaust emission" in accordance with directive 97/68/EC TIER 3A



## ENGINE MULTIPLE WORK MODES

This latest generation CNH TIER 3A common rail engine, electronically controlled, features **multiple work modes**. According to the type of application, the operator can select the following engine power modes:

- **Maximum power**.....169 kW/227 hp, for very tough conditions
- **Standard power**.....157 kW/210 hp, for normal loading conditions
- **Economy power**..142 kW/190 hp, for light load & carry applications
- **Automatic power mode** to automatically match the power curve to the application.

Perfect electronic control to get the best performances in every type of job while contributing to reduced fuel consumption.



## ELECTRICAL SYSTEM

Voltage .....24 V  
 Batteries, in series .....2  
 - capacity.....160 Ah  
 - type .....maintenance-free  
 Starter motor.....7.8 kW  
 Alternator capacity .....70 A



## TORQUE CONVERTER

Type .....single stage / single phase  
 Torque multiplication ratio .....2.28 : 1



## TRANSMISSION

Type: Power-Shift countershaft design with four forward and three reverse speeds

Control: single lever electric "fingertip" type.

Forward speeds.....km/h  
 1.....7.1  
 2.....12.6  
 3.....23.3  
 4.....37.0  
 Reverse speeds  
 1.....7.9  
 2.....13.8  
 3.....25.3  
 with 23.5-25 tyres

Safety device prevents engine starting in gear

**Electronic Transmission System (ETS):** allows the operator to dedicate attention to the work cycle.

The on-board computer automatically finds the right gear in relation to the type of work.

**HOLD** function to maintain selected speed with the machine operating on a slope.

**KICK-DOWN** function to shift from 2nd to 1st gear when high pushability is required.

**DOWNSHIFT** function to select the most suitable speed with the machine on a slope. Low gears favour the use of the engine brake function and consequently reduce brake use.

Forward and reverse control switch.



## AXLES

Rigid front axle, oscillating rear axle designed for heavy duty applications

Rear axle oscillation.....24°

Rear wheel vertical travel .....502 mm  
 "Limited Slip" differentials

Hermetically sealed final drives and wet disc brakes



## BRAKES

**Service brakes**.....self-adjusting

Type .....wet disc brakes on all four wheels

Servo-assisted hydraulic brake circuit

Independent circuit for each axle

Control pedal located to left of steering column

Electrical transmission disengagement switch

The brake circuit complies with the following international standards:

ISO 3450, CEE 71/320, SAE J1473

**Parking brake:** spring applied hydraulically released caliper disc brake on trasmission output shaft.

Electrical control by means of switch in cab.



## TYRES

Type .....Tubeless

Radial .. 23.5-25 GP-2B

23.5-25 XHA

650/65R25XLD

23.5-25 XLDD2



## HYDRAULIC SYSTEM

Type .....load sensing circuit, closed centre

Pumps .....2 - variable displacement -axial pistons

feeding the integrated implement and steering system

Max. flow delivery.....240 l/min

Max. working pressure .....250 bar

Control valve .....2 spool  
 3 spool

Control .....piloted dual lever  
 piloted, single lever

Double-acting hydraulic cylinders

booms.....	2
bore x stroke.....	133 x 846 mm
bucket .....	1
bore x stroke.....	165 x 600 mm
Operating time	
lift .....	5.6 s
lower .....	2.7 s
dump .....	1.2 s

Hydraulic lines and connecting flanges are equipped with O-ring seals.

**L.T.S. device**

Load Travel Stabiliser. Invaluable for loading and transport on uneven terrain.

 **STEERING**

Type.....**Orbitrol**, hydraulically actuated with priority valve  
 Pump .....utilise one of the hydraulic system pumps  
 Max. flow rate .....120 l/min  
 Max. working pressure .....248 bar  
 Cylinders .....2, double acting  
   bore x stroke.....83 x 482 mm  
 Emergency steering circuit with electric motor activated by the onboard computer.

 **CAB**

ROPS/FOPS modular cab.  
 Excellent all-round visibility.  
 The ROPS/FOPS cab complies with the following standards:  
 ROPS - EN13510  
 FOPS - EN ISO 3449

 **CAPACITIES**

Engine	Litres
Lube oil .....	19
Coolant .....	41
Fuel tank .....	288
TRANSMISSION	
Transmission converter oil.....	40
hydraulic system.....	174
AXLES: front/rear.....	37/24



# W190B

## DIMENSIONS mm

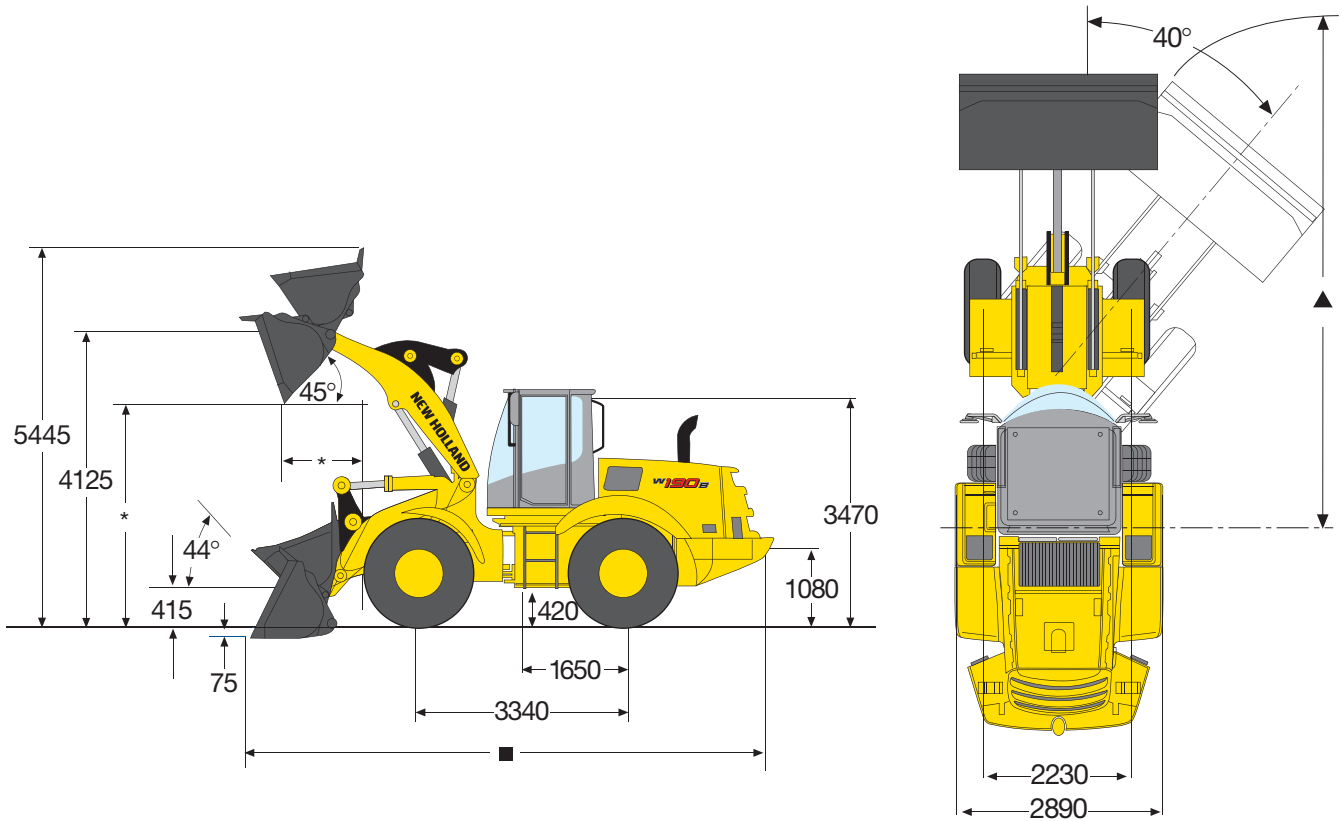

## PERFORMANCE

### GENERAL PURPOSE

BUCKET TYPE		WITH TEETH AND SEGMENTS		WITH CUTTING EDGE EXTENSION		WITH TEETH	
Bucket capacity	m <sup>3</sup>	3.2	3.5	3.2	3.5	3.1	3.4
Bucket weight	kg	1720	1750	1660	1690	1600	1630
Bucket width	mm	3000	3000	3000	3000	3000	3000
Dump height at 45° *	mm	2810	2790	2935	2910	2810	2790
Reach at 45° *	mm	1265	1290	1210	1235	1265	1290
Overall length (bucket on ground) ■	mm	8100	8135	7935	7970	8100	8135
Turning radius ▲ (bucket at carry position)	m	6.7	6.7	6.6	6.6	6.7	6.7
Breakout force	daN	17500	16200	16500	15200	17500	16200
Static tipping load: 0°	kg	14340	14300	14420	14370	14500	14450
40°	kg	12350	12300	12420	12370	12500	12450
Max operating weight	kg	17570	17600	17510	17540	17450	17480

\* At bucket cutting edge

Note: All performance data and specifications based on a unit with 23.5-25 XHATL radial tyres and ROPS cab. All data is obtained in compliance with the latest applicable SAE Recommended Practices including J732c, J742b and ISO 6746/1, ISO 6746/2 and ISO 8313.

# PERFORMANCE “LONG BOOM”

## GENERAL PURPOSE

BUCKET TYPE		WITH CUTTING EDGE EXTENSION
Bucket capacity	m <sup>3</sup>	3.2
Bucket weight	kg	1560
Bucket width	mm	3030
Dump height at 45°	mm	3380
Reach at 45° (at 2130 mm height)	mm	2120
Overall length (bucket on ground)	mm	8370
Overall height (bucket raised)	mm	5895
Turning radius (at bucket edge)	m	6.89
Breakout force	kg	16270
Static tipping load:	kg	11425
0°		
40°	kg	9790
Operating weight	kg	18390



Note: All performance data and specifications based on a unit with 26.5-25 XHA radials tyres and ROPS cab.  
All data is obtained in compliance with the latest applicable SAE Recommended Practices including J732c, J742b and ISO 6746/1, ISO 6746/2 and ISO 8313.

## BUCKET SELECTIONS

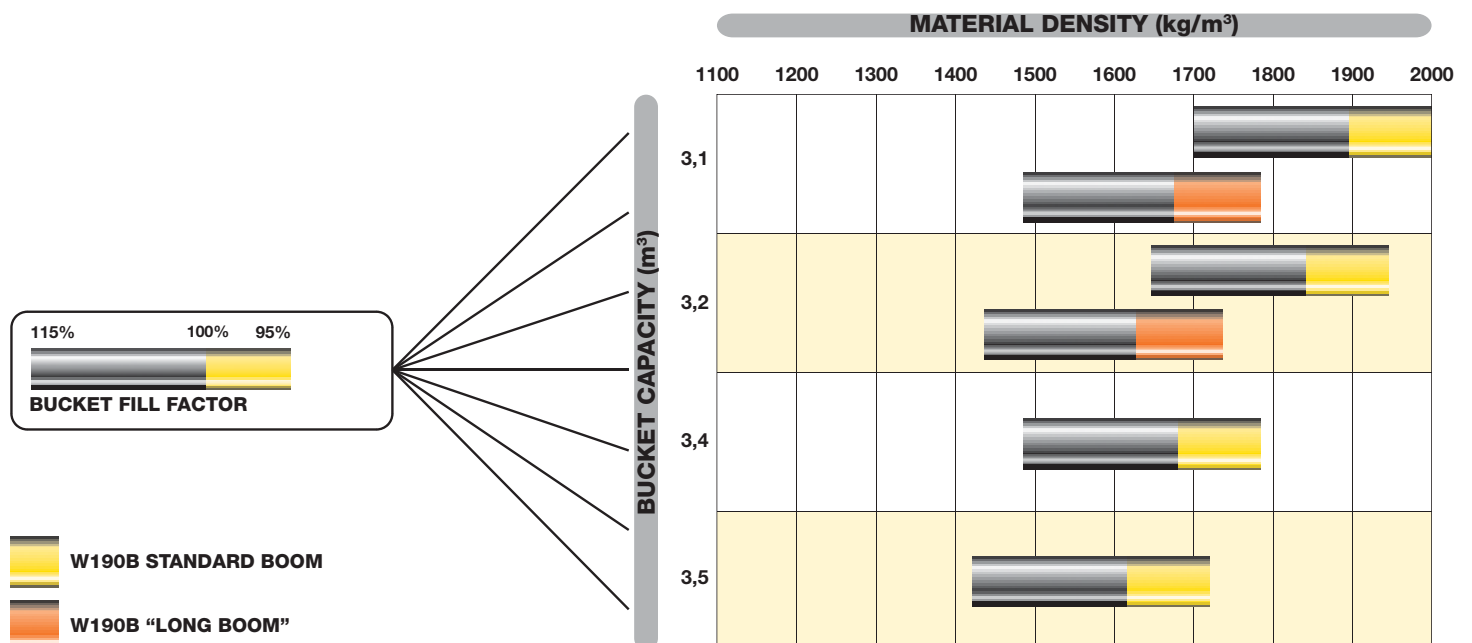

# STANDARD EQUIPMENT

- 70 A alternator voltage regulator
- Antifreeze
- Automatic return-to-dig
- Two batteries of 160 Ah each
- Bucket and lift levers with hydraulic power assist and electromagnetic detent
- Bucket position indicator
- Centrally located fuse box
- A.C.S., Advanced Cooling Module centrally mounted with integrated hydraulic oil tank for: - transmission oil - engine coolant - hydraulic oil - air to air aftercooler - air conditioner condenser (if equipped)
- Electrical disconnect
- Emergency steering
- Four-wheel drive
- Front and rear halogen flood lights
- Full flow hydraulic system with 10 micron filter
- Horn
- Hydraulic driven fan
- Hydraulic wet disc brakes
- Instrumental Cluster:
  - Analog Gauges:**
    - Transmission Temperature - Engine Coolant Temperature
    - Hydraulic Oil Temperature - Fuel Level
  - Audible and Visual alarms:**

- Cautionary and critical Levels - Directional/Brights Indication
- Low Fuel - Directional Signals - Low Oil Pressure
- LCD Screen:**
  - Hour Meter - Time - F/N/R Indication - Trip computer
  - Metric/English - Warning Prompts - Engine Speed
  - Automatic Trans Indication - DeClutch Indication
  - Fuel Consumption - Engine Diagnostic - Error Reporting
  - Travel Speed - Current Gear Selection - Engine Mode Indication
  - Multiple Languages - Transmission Diagnostics
- Limited slip differentials axles
- Planetary axles
- Power steering
- Remote drain points
- Retractable seat belt
- ROPS/FOPS Cab
- Single lever electrically actuated proportional Powershift transmission
- Side covers
- Spring applied hydraulic releases disc parking brake
- Suspended and adjustable cloth seat
- Tail lights and stop lights combined
- Tilt steering column
- Tubeless tires
- Two-element dry-type air cleaner

# OPTIONS

- 2 spool valve with joystick
- 3 spool valve with 3 levers
- 3 spool valve with joystick and 1 lever
- Air suspended and fully adjustable cloth seat
- Automatic Airconditioner
- Buckets selection with teeth and cutting edge
- Cold weather package
- Fire extinguisher
- Full view air precleaner
- Head rest
- Italian homologation
- LTS Load Travel Stabiliser
- Quick Coupler
- Radio
- Rotating beacon
- Transmission guard
- Transfer fuel pump kit
- Tool box
- TUV homologation
- Wide choice of tyres
- Wide fenders with LH and RH steps

Note: standard and optional equipment may vary by country. Consult your NEW HOLLAND dealer for specific details.

AT YOUR OWN DEALERSHIP

The information contained in this brochure is intended to be a general nature only. The NEW HOLLAND KOBELCO CONSTRUCTION MACHINERY S.p.A. company may at any time and from time to time, for technical or other necessary reasons, modify any of the details or specifications of the product described in this brochure. Illustrations do not necessarily show products in standard conditions. The dimensions, weights and capacities shown herein, as well as any conversion data used, are approximate only and are subject to variations within normal manufacturing techniques.

Published by NEW HOLLAND KOBELCO CONSTRUCTION MACHINERY S.p.A.  
Printed in Italy - LEADER Firenze - Cod. 30 341GB - Printed 04/09

Printed on recycled paper  
CoC-FSC 000010 CQ Mixed sources



BUILT AROUND YOU

www.newholland.com