



NEW HOLLAND

W190_B WASTE HANDLER



1
FRONT GLASS
CAB PROTECTION



2
ENGINE PRECLEANER
WITH SCREEN



3
HYDRAULIC
REVERSIBLE FAN



4
REAR GRILLE GUARD



5
ARTICULATION
PROTECTION



6
BOTTOM
GUARD



7
FRONT FRAME &
AXLE PROTECTION



8
CYLINDERS
PROTECTION

WASTE HANDLER CONTENTS

MAXIMUM POWER	169 kW - 227 hp
MAX OPERATING WEIGHT	19 800 kg
HIGH DUMP BUCKET CAPACITY	3.5 m ³



BUILT AROUND YOU

ADDITIONAL FEATURES



AUTOMATIC GREASING SYSTEM



FLEXIBLE LADDER STEP



FRONT LIGHT GUARDS

SPECIFICATIONS

Machine equipped with MICHELIN tyres 23.5 R 25 XMINE-D2

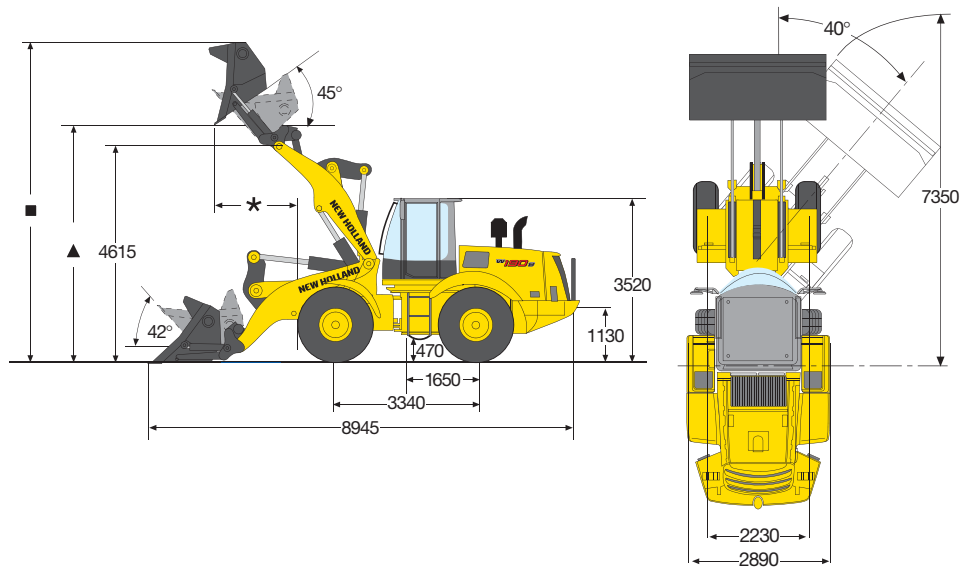

BUCKET TYPE		DUMP HEIGHT BUCKET
Bucket capacity	m ³	3.5
Bucket weight	kg	2500
Bucket width	mm	3000
Dump height at 45° (Bucket retracted/tipped) (▲)	mm	3430/4745
Reach at 45° (Bucket retracted/tipped) (★)	mm	1220/1310
Overall length (Bucket on ground)	mm	8945
Overall height (Bucket retracted/tipped) (■)	mm	6015/6590
Turning radius (at bucket edge)	m	7.35
Breakout force (Bucket retracted)	daN	15500
Static tipping load: (with bucket retracted) 0°	kg	10100
Static tipping load: (with bucket retracted) 40°	kg	8650
Operating weight	kg	19.800

AT YOUR OWN DEALERSHIP

The information contained in this brochure is intended to be a general nature only. The NEW HOLLAND KOBELCO CONSTRUCTION MACHINERY S.p.A. company may at any time and from time to time, for technical or other necessary reasons, modify any of the details or specifications of the product described in this brochure. Illustrations do not necessarily show products in standard conditions. The dimensions, weights and capacities shown herein, as well as any conversion data used, are approximate only and are subject to variations within normal manufacturing techniques.

Published by NEW HOLLAND KOBELCO CONSTRUCTION MACHINERY S.p.A.
Printed in Italy - LEADER Firenze - Cod. 30 603GB - Printed 04/09

Printed on recycled paper
CoC-FSC 000010 CQ Mixed sources



**FIAT
GROUP**



www.newholland.com